

DUAL FACE UNIT

Block Wt.	3,520 lbs	1,595 kg
Form Wt.	2,430 lbs	1,100 kg
Concrete Volume	0.88 CY	0.67 m ³

DUAL FACE HALF UNIT

Block Wt.	1,760 lbs	800 kg
Form Wt.	2,430 lbs	1,100 kg
Concrete Volume	0.44 CY	0.34 m ³

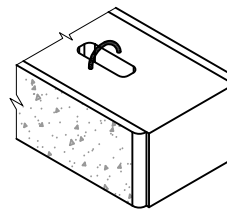
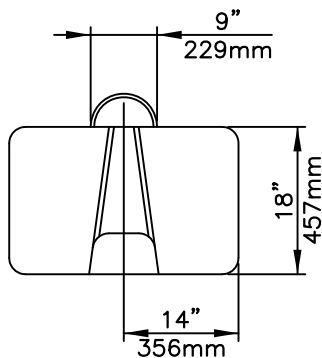

ALTERNATE FINISHED END